



VESTIL MANUFACTURING CORP.

2999 North Wayne Street, P.O. Box 507, Angola, IN 46703
 Telephone: (260) 665-7586 -or- Toll Free (800) 348-0868
 Fax: (260) 665-1339
www.vestilmfg.com e-mail: sales@vestil.com

**PLB-SERIES WOODEN PRY LEVER BARS
 ASSEMBLY MANUAL**



Receiving instructions:

After delivery, IMMEDIATELY remove the packaging from the product in a manner that preserves the packaging and maintains the orientation of the product in the packaging; then inspect the product closely to determine whether it sustained damage during transport. **If damage is discovered during the inspection, immediately record a complete description of the damage on the bill of lading.** If the product is undamaged, discard the packaging.

NOTES:

- 1) Compliance with laws, regulations, codes, and non-voluntary standards enforced in the location where the product is *used* is exclusively the responsibility of the owner/end-user.
- 2) VESTIL is **not liable** for any injury or property damage that occurs as a consequence of failing to apply either:
 a) Instructions in this manual; or b) information provided on labels affixed to the product.

Table of Contents:

Signal Words.....	2
Safe Use Recommendations.....	2
Product Specifications.....	2
Labeling Diagram.....	2
FIG. 1: PLB exploded parts diagram & bill of materials.....	3
Assembly instructions.....	3
Use instructions.....	3
Inspections.....	3
Maintenance.....	4
Limited Warranty.....	4

Signal Words

This manual uses SIGNAL WORDS to indicate the likelihood of personal injuries, as well as the probable seriousness of those injuries, if the product is misused in the ways described. Other signal words call attention to uses of the product likely cause property damage.

The signal words used appear below along with the meaning of each word:



DANGER Identifies a hazardous situation which, if not avoided, **WILL** result in **DEATH** or **SERIOUS INJURY**. Use of this signal word is limited to the most extreme situations.



WARNING Identifies a hazardous situation which, if not avoided, **COULD** result in **DEATH** or **SERIOUS INJURY**.



CAUTION Indicates a hazardous situation which, if not avoided, **COULD** result in **MINOR** or **MODERATE** injury.



NOTICE Identifies practices likely to result in product/property damage, such as operation that might damage the product.

Each person who assembles, installs, uses, or maintains this product should read the entire manual **in advance and fully understand the directions**. If after reading the manual you do not understand an instruction, ask your supervisor or employer for clarification, because failure to adhere to the directions in this manual might result in serious personal injury.

Safe use recommendations:

Vestil diligently strives to identify foreseeable hazards associated with the use of its products. However, material handling is inherently dangerous and no manual can address every conceivable risk. The end-user ultimately is responsible for exercising sound judgment at all times.



WARNING Improper use could result in serious personal injuries.

- *Failure to read and understand the entire manual before assembling, using or servicing the pry bar is a misuse of the product.* Read the manual to refresh your understanding of proper use and maintenance procedures.
- DO NOT exceed the maximum rated load (see Label 287 on product; also shown below).
- Only use the pry bar on improved surfaces (concrete or asphalt).
- DO NOT apply more than 150 lb. downward force on the end of the handle.
- DO NOT hang on, sit on, or bounce on the pry bar while attempting to tip or hold a load.
- ALWAYS carefully watch the load on the pry bar.
- Inspect the pry bar before each use (see "Inspections & Maintenance" on p. 3-4). DO NOT use the device unless it is in satisfactory condition.
- DO NOT use the pry bar to transport loads. Only use the bar to lift an edge or a corner of a load.
- DO NOT lean over the pry bar while using it to lift a load.
- DO NOT use the pry bar if it is damaged.
- DO NOT modify the pry bar in any way. **Unauthorized modifications automatically void the limited warranty (see p. 4) and might make the product unsafe to use.**

Product Specifications:

Model	Description	Bar Length	Caster Dimensions	Caster Type	Maximum Rated Load	Net Weight
PLB-5	Wooden pry bar	5 ft.	5in. x 2in.	Poly-on-steel	4,250 lb. 1,931.8 kg	31 lb. 14.1 kg
PLB-6	Wooden pry bar	6 ft.	5in. x 2in.	Poly-on-steel	4,250 lb. 1,931.8 kg	32.1 lb. 14.6 kg
PLB-7	Wooden pry bar	7 ft.	5in. x 2in.	Poly-on-steel	4,250 lb. 1,931.8 kg	33.2 lb. 15.1 kg

Label Placement Diagram:

The product should always be labeled as shown in the diagram to the right. Replace any label that is damaged and/or not easily readable.



Label 287: Model, serial no., capacity
(Applied to back side of axle)

MODEL/MODÉLO/MODÈLE _____
 STATIC CAPACITY (evenly distributed) _____ lbs.
 LA CAPACIDAD CONSTANTE (distribuida uniformemente) _____ kgs.
 CAPACITÉ STATIQUE (distribuée régulièrement) _____ kgs.
 SERIAL/SERIE/SÉRIE _____

287 REV 0812

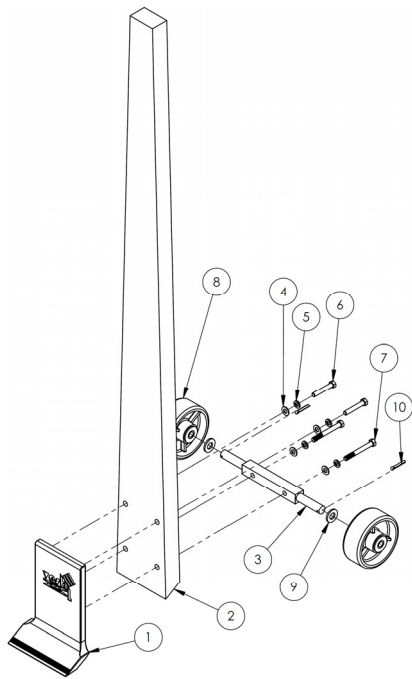
FIG. 1: PLB-series pry bars exploded parts diagram and bill of materials

Item no.	Part no.	Description	Quantity
1	33-014-006	Pry plate	1
2		Wooden handle:	
	33-014-003	PLB-5	1
	33-014-004	PLB-6	1
	33-014-005	PLB-7	1
3	33-112-004	Axle	1
4	33082	$\frac{3}{8}$ in. SAE zinc-plated flat washer	4
5	33622	$\frac{3}{8}$ in. zinc-plated lock washer	4
6	11112	$\frac{3}{8}$ in. -16 x $2\frac{1}{4}$ in. HHCS bolt	2
7	11116	$\frac{3}{8}$ in. -16 x $3\frac{1}{4}$ in. HHCS bolt	2
8	16-132-020-001	5in. x 2in. poly on steel wheel, roller bearing, for $\frac{3}{4}$ in. axle	2
9	33424	$\frac{3}{4}$ in. x 18ga. machine bushing	4
10	65125	$\frac{3}{16}$ in. x $1\frac{1}{2}$ in. zinc-plated cotter pin	2
*	13-154-006	Complete replacement wheel kit (items numbered 8, 9, & 10)	
*	33-154-002	Complete replacement hardware kit	

Assembly instructions: To assemble the pry bar, complete the following steps.

- 1) Attach the wheels to the axle:
 - a. Put a machine bushing (9) onto each end of the axle (3);
 - b. Slide a wheel (8) onto each end of the axle; then
 - c. Secure the wheels to the axle by inserting cotter pins (10) through the pin holes in the ends of the axle.
- 2) Fasten the upper part of the pry plate to the handle.
 - a. Put a lock washer (5) and then a flat washer (4) on each of the shorter bolts (6);
 - b. Place the pry plate (1) against the handle (2) and align the bolt holes in the handle with the threaded holes in the back side of the pry plate.
 - c. Insert the bolts through the upper bolt holes in the handle and wind them into the upper holes in the pry plate. Do not tighten the connections at this time.
- 3) Fasten the wheel assembly (from step 1) to the handle and pry plate.
 - a. Put a lock washer and then a flat washer on each of the longer bolts (7);
 - b. Make sure that the lower bolt holes in the handle align with the lower threaded holes in the pry plate.
 - c. Insert the bolts through the axle, through the lower bolt holes in the handle, and wind them into the pry plate.
- 4) Tighten all connections.

Use instructions: To lift an object with the pry bar,

- 1) Slide the pry plate under the object. Apply steady pressure to the axle to push the plate under the object; then
- 2) Carefully pull down the end of the handle. Make sure that the pry plate does not slip out from under the object.

Inspections: Perform the inspections explained below and maintain the pry bar as described to ensure that the unit is and remains in normal, safe operating condition.

⚠ WARNING If a problem is discovered during an inspection, restore the unit to normal operating condition **BEFORE** using it again. DO NOT use the unit if repairs are incomplete! While servicing the pry bar, DO NOT modify it in any way. A "modification" is a change that alters the product from original condition, like bending the structural members or removing parts. Modifications might make the device unsafe to use and *automatically* void the limited warranty.

Before each use, including first use, inspect:

1. Handle and pry plate: look for regions of significant wear, cracks, deformation and rot.
2. Wheels and mounting hardware: roll the pry bar to confirm that the wheels and bushings are in normal condition. Examine the axle, machine bushings and cotter pins. The axle should be straight and undamaged. Bushings should be undamaged and allow the wheels to turn smoothly without contacting the cotter pin. The cotter pin should be undamaged and securely attached to the axle pin.
3. Product labels: all labels should be readable and located as shown in the "Label placement diagram" on p. 4. If a label is unreadable or missing, contact Vestil to order a replacement.

Maintenance:**NOTICE**

Proper use, maintenance, and storage are essential for this product to function properly.

- Always use the pry bar as described in this instruction manual.
- ONLY install replacement parts supplied or approved by the manufacturer.
- ALWAYS store the pry bar in a dry location.

- 1: Remove any dirt or other matter from all surfaces.
- 2: Inspect the pry bar as described above. If deformity, rot, or excessive wear is discovered DO NOT use the product.
- 3: Perform all necessary adjustments, replacements and/or repairs.
- 4: Make a dated record of any repairs, adjustments and/or replacements.

LIMITED WARRANTY

Vestil Manufacturing Corporation ("Vestil") warrants this product to be free of defects in material and workmanship during the warranty period. Our warranty obligation is to provide a replacement for a defective original part if the part is covered by the warranty, after we receive a proper request from the warrantee (you) for warranty service.

Who may request service?

Only a warrantee may request service. *You are a warrantee if* you purchased the product from Vestil or from an authorized distributor AND Vestil has been fully paid.

What is an "original part"?

An original part is a part used to make the product as shipped to the warrantee.

What is a "proper request"?

A request for warranty service is proper if Vestil receives: 1) a photocopy of the Customer Invoice that displays the shipping date; AND 2) a written request for warranty service including your name and phone number. Send requests by any of the following methods:

<u>Mail</u>	<u>Fax</u>	<u>Email</u>
Vestil Manufacturing Corporation 2999 North Wayne Street, PO Box 507 Angola, IN 46703	(260) 665-1339 <u>Phone</u> (260) 665-7586	sales@vestil.com

In the written request, list the parts believed to be defective and include the address where replacements should be delivered.

What is covered under the warranty?

After Vestil receives your request for warranty service, an authorized representative will contact you to determine whether your claim is covered by the warranty. Before providing warranty service, Vestil may require you to send the entire product, or just the defective part or parts, to its facility in Angola, IN. The warranty covers defects in the following *original* dynamic components: motors, hydraulic pumps, electronic controllers, switches and cylinders. It also covers defects in *original* parts that wear under normal usage conditions ("wearing parts"): bearings, hoses, wheels, seals, brushes, batteries, and the battery charger.

How long is the warranty period?

The warranty period for original dynamic components is 90 days. For wearing parts, the warranty period is 90 days. The warranty periods begin on the date when Vestil ships the product to the warrantee. If the product was purchased from an authorized distributor, the periods begin when the distributor ships the product. Vestil may, at its sole discretion, extend the warranty periods for products shipped from authorized distributors by *up to* 30 days to account for shipping time.

If a defective part is covered by the warranty, what will Vestil do to correct the problem?

Vestil will provide an appropriate replacement for any *covered* part. An authorized representative of Vestil will contact you to discuss your claim.

What is not covered by the warranty?

1. Labor;
2. Freight;
3. Occurrence of any of the following, which automatically voids the warranty:
 - Product misuse;
 - Negligent operation or repair;
 - Corrosion or use in corrosive environments;
 - Inadequate or improper maintenance;
 - Damage sustained during shipping;
 - Collisions or other incidental contacts causing damage to the product;
 - Unauthorized modifications: DO NOT modify the product IN ANY WAY without first receiving written authorization from Vestil. Modification(s) might make the product unsafe to use or might cause excessive and/or abnormal wear.

Do any other warranties apply to the product?

Vestil Manufacturing Corp. makes no other express warranties. All implied warranties are disclaimed to the extent allowed by law. Any implied warranty not disclaimed is limited in scope to the terms of this Limited Warranty.

